



# Operation Manual

DC Voltage Measuring Amplifier with Data Logger

## GM 80-TG/-PA





# 1 Imprint

<i>Manufacturer, Place</i>	<i>Lorenz Messtechnik GmbH, D-73553 Alfdorf</i>
<i>Valid for...</i>	<i>DC Voltage Measuring Amplifier GM 80-TG/PA</i>
<i>Copyright Note</i>	<i>© 2006 - 2014 Lorenz Messtechnik GmbH, Alfdorf</i>
<i>Interdiction of Reprint</i>	<i>Reprint in whole or in part with written permission, only.</i>
<i>Change Notice</i>	<i>Technical changes are reserved.</i>



## 2 Notes

### 2.1 General Notes

This operation manual is intended for technically qualified personnel with appropriate skills in the field of measurement and automatic control techniques. The information regarding all safety precautions and warnings in this manual as well as their flawless technical implementation is prerequisite for the safe installation, the commissioning, the safe operation and maintenance of **Lorenz Messtechnik GmbH** devices. Therefore it is imperative that all measures are carried out by qualified personnel, only. All persons involved with project planning, installation and operation of **Lorenz Messtechnik GmbH** devices must be familiar with the safety concepts in automation and control technology and qualified in the above mentioned sense.

For the sake of clarity, this operation manual may not constitute a detailed use of **Lorenz Messtechnik GmbH** devices in all possible applications. Also, not all possible types of installation, operation and maintenance are considered. If further information is required or should particular problems arise, which are not or not sufficiently detailed represented in this manual, please request this information from **Lorenz Messtechnik GmbH**.

**The safety precautions must be observed in order to prevent property damage, injuries and/or even death results.**

**Lorenz Messtechnik GmbH devices may only be operated in accordance with the applications prescribed in this manual. Built-in appliances may be used in professional installations, only.**

With the connection and commissioning of the device, the buyer accepts the General Terms of Sale and Delivery of **Lorenz Messtechnik GmbH**. Furthermore, the buyer accepts possible incompleteness of the manual and that information described therein is subject to change. Errors and changes are reserved.

#### Provisions for Use

A **Lorenz Messtechnik GmbH** device is used for displaying, processing and controlling of processes. It may not be used as a sole instrument for the prevention of dangerous conditions of machines and plants. Machinery and equipment must be designed in a way that erroneous states do not lead to a dangerous situation for operators (e.g. by independent limit switches, mechanical interlocks). In particular, it must be ensured that an incorrect entry on the device, its malfunction or failure does not lead to property damage or cause hazard to persons. It is also important to prevent the evasion of the security provisions of a plant. Emergency stop equipment must always be active.

#### Installation Notes

**Lorenz Messtechnik GmbH** devices must be installed and connected in compliance with the relevant DIN and VDE Standards. They must be installed in a way that inadvertent operation is sufficiently excluded. In order to avoid an undefined or hazardous state caused by interruption of the supply and signal lines, the appropriate hardware and software-related safety precautions must be observed. Supply and signal lines must be installed in such way that impairment of function of **Lorenz Messtechnik GmbH** devices cannot be caused by interfering signals (such as inductive or capacitive interference).



### **Malfunction, Maintenance and Repair Notes**

The devices do not contain parts which need or can be serviced by the user. Repairs may be carried out by **Lorenz Messtechnik GmbH**, exclusively. If assuming that safe operation of the device is no longer possible, it must be taken out of service and secured against inadvertent operation, immediately. This applies in particular, if:

- the device shows visible damage
- the device is no longer functional
- parts of the device are loose
- the connection lines show visible damage

It is also pointed out that all obligations of **Lorenz Messtechnik GmbH** are exclusively arising from the respective sales contract in which the warranty is conclusively settled.

## **2.2 Intended Use**

**Lorenz Messtechnik GmbH** devices may only be used for measurement tasks and the directly related control tasks. Any other use is considered improper.

## **2.3 General Dangers by not following the Safety Precautions**

The device complies with the state of current safety requirements. Residual risks can occur, if the device is improperly used and operated by untrained personnel. Any person commissioned with the installation, operation and maintenance of the device must have read and understood the operation manual and the safety precautions, in particular.

## **2.4 Residual Dangers**

The device only covers part of the scope of measurement technology. Safeguarding interests of the measurement technology must be planned and realized by the plant designer/supplier in a way to minimize residual dangers. The valid rules regulations and laws must be observed. Residual risks in connection with measurement technology must be pointed out.



## 2.5 Safety and Caution Symbols

If residual risks occur while working with the device, the following symbols in this operation manual must be noted:

**Warning:**

Warns of a potential risk of serious life-threatening injuries. The accident prevention regulations of the employer's liability insurance association must be considered.

**Caution:**

Warns of a potential danger of damage for the device, process, persons, or environment.

**Note:**

Supplemental information.

**Important / Tip:**

Reference to more detailed technical information.

## 2.6 Notes regarding the CE - Label

As a manufacturer, we guarantee with the CE – Label that our product meets the requirements of the relevant European Union directives. The devices of the GM 80-TG/-PA family are designed for the use in industrial environments and meet the requirements for emission according EN 61000-6-4 and for immunity according EN 61000-6-2.

## 2.7 Health Protection and Safety

To ensure that our products are safe and do not pose health hazard, following points must be considered:

1. All relevant sections of this manual must be read attentively in prior to the operation.
2. All warning labels on containers and packages must be noted.
3. Installation, operation and maintenance work may only be carried out by accordingly trained personnel under observance of the given instructions. If one of these instructions is not considered, the user of the product bears the complete responsibility for all consequences, occurring from the failure to comply.
4. Before opening the device, it must be disconnected from any power supply.
5. The device meets the safety requirements of DIN EN 61010 Part 1 (VDE 0411 Part 1) Protection Class III

## 2.8 Qualified Personnel

Qualified personnel are persons who are familiar with the installation, operation and the maintenance of the device and have appropriate qualifications. The device shall only be used by qualified personnel according to the technical data in connection with the following safety regulations and rules. During the operation, legal and safety rules for the respective application case must be noted. The same applies for the use of accessories.

## 2.9 Changes

The device may not be changed constructively or safety-related without the explicit permission of **Lorenz Messtechnik GmbH**. Any modification shall exclude liability on our part for damages resulting from this. Repairs and changes to the circuit boards are prohibited.



### 3 **Continuative Documents**

Following documents contain reference information about GM 80-TG/-PA

- 170197.pdf, Connection of a printer to the GM 80-TG/-PA



## 4 Contents

1	Imprint.....	2
2	Notes .....	3
2.1	General Notes .....	3
2.2	Intended Use.....	4
2.3	General Dangers by not following the Safety Precautions .....	4
2.4	Residual Dangers.....	4
2.5	Safety and Caution Symbols .....	5
2.6	Notes regarding the CE - Label .....	5
2.7	Health Protection and Safety .....	5
2.8	Qualified Personnel .....	5
2.9	Changes.....	5
3	Continuative Documents .....	6
4	Contents .....	7
5	Introduction .....	8
5.1	Product Description .....	8
5.2	Power Supply .....	8
5.3	Safe and Proper Use.....	8
5.4	Dimensions – Weight.....	8
6	Instruction / Description of the Operating Mode.....	9
6.1	Switching the GM 80-TG/-PA on .....	9
6.2	Digital Inputs .....	9
6.2.1	Trigger – Input.....	9
6.2.2	Enable – Input.....	9
6.2.3	Tare/GWS2 – Input .....	9
6.3	Digital Outputs – Limit Values (SP1 and SP2).....	10
6.4	Key Assignment in the Menu .....	10
6.5	Operation Examples.....	10
6.6	Measuring with the GM 80-TG/-PA.....	11
6.6.1	Selected Sensor .....	11
6.6.2	Sensor Parameters .....	11
6.6.3	Measuring with the GM 80-TG/PA Measuring Amplifier.....	11
6.7	GM 80-TG/-PA Brief Operation Overview .....	12
6.8	Menu Description .....	13
6.9	Calibration/Adjustment Procedure .....	15
6.10	Edit and Adjust Limit Values .....	16
6.11	Configuration and Adjustment of the Peak Value and the Instantaneous Value Memory .....	16
6.12	Serial Interface .....	20
6.12.1	Transfer rate/specification RS232 / V.24 .....	20
6.12.2	Protocol overview .....	20
6.12.3	Connection to a serial interface .....	23
6.12.4	Operation and function principle of the GM 80-TG/PA.....	23
6.13	Pin Assignment .....	25
6.13.1	Connection example digital input (BMS plug) .....	26
6.13.2	Connection example digital input (BMS plug) .....	26
7	Product Phases.....	27
7.1	Transportation .....	27
7.2	Commissioning and Installation .....	27
7.3	Standard Operation .....	27
7.4	Maintenance and Cleaning .....	28
7.5	Safe Disposal .....	28



## 5 Introduction

This manual describes the features and installation procedures of the DC Voltage Measuring Amplifier GM 80-TG/-PA.

### 5.1 Product Description

The GM 80 TG / PA is a DC Voltage Measuring Amplifier for passive and active sensors or sensors with a current interface.

GM80 TG	Table device with 24 V DC power supply
GM80 PA	Panel device 144 x 72 norm, cut-out in cabinet: 138 x 68 mm
Inputs:	Passive (SG) 0,35-3,3mV/V; active: 0-1V...0-5V / 0/4 – 20mA
Data logger :	can store up to 3000 measured values. For short- to long-term measurements with many operating modes.
RS 232:	Data transfer or queries of the measured or logged values to a pc or a printer.
10 parameter sets:	Here, the calibration data, the sensor designation and the physical unit are stored.
Control inputs:	3 optocoupler inputs with functions such as data logging, RS232-issue, delete memory, tare or second limit value set.
Limit values:	2 very fast PhotoMos relays are freely configurable as closing contacts.
Measuring functions:	Tare, min./max. value and delete min./max., during the measurement.

If the GM 80 TG / PA is being delivered with one or more sensors, these sensors will be adjusted to the GM 80 TG / PA and are ready for operation immediately.

The assignment of these sensors to the corresponding parameter set is documented on the rear panel.

### 5.2 Power Supply

#### Mains operation:

Power supply of 24V DC / 250mA is part of the delivery scope of the GM 80-TG.

The supply voltage of 16 – 30V DC is connected to the GM 80-PA via a BMS-plug.

#### Battery for date and time:

a standard CR2032 lithium coin cell battery with 3V is used. If time and date continuously begins at 0:00hrs on 01.01.70, the battery should be replaced.

- **First switch the GM 80 – TG/PA off power!!!**
- Open the housing:
  - Loosen both screws at the bottom of the GM 80-TG and remove the housing top cover.
  - Remove the front frame at the GM 80-PA and slightly lift off the front foil on all 4 corners, then loosen the underlying screws. Now, carefully pull out the circuit board.
- The battery is fixed in a holder on the board and can be easily replaced. The positive pole of the battery is facing up (visible after insertion)!

### 5.3 Safe and Proper Use

Caution:



- Protect the device against moisture, condensation, rain, snow....
- Protect the device against direct solar radiation
- Protect the device against dust and pollution
- Protect the device against excessive ambient temperature
- Protect the device against excessive vibration

### 5.4 Dimensions – Weight

GM80/TG in mm:	160 x 76 x 134	Weight: 0.5 kg
GM80/PA in mm	144 x 72 x 120	Weight: 0,5 kg
cutout for GM80/PA in mm:	138 +1 x 68 +0,7	



## 6 Instruction / Description of the Operating Mode

### 6.1 Switching the GM 80-TG/-PA on

- The GM 80-TG is activated by pressing ENTER.
- The GM 80-PA is activated by switching the supply voltage.

### 6.2 Digital Inputs

The device has an electrically isolated control input: Trigger, Enable, Tara/GWS2. These inputs can be controlled by e.g. a PLC, a remote switch, a foot switch etc. As a control signal, following voltage levels for each logic state must be applied to the phone jack:

Logic State	Low Level	High Level
Voltage Level	0 V – 2 V	3,5 V – 27 V
State	inactive	active

#### 6.2.1 Trigger – Input

Depending on adjustment, data can be logged or interface data can be issued. This input has a high sampling rate, thus very short pulses will be detected.

BMS plug: Trigger                      Signal (Pin3)    0V (Pin11 or Pin12)

#### 6.2.2 Enable – Input

With this feature, the **Maximum and Minimum Value** is deleted externally.

In setting „2.9 INPUT → DISPLAY → **Max** or **Min**“ e.g. the maximum and minimum value can be reset after each measurement in order to determine the next extreme value.

BMS plug: Enable                      Signal (Pin4)    0V (Pin11 or Pin12)

#### 6.2.3 Tare/GWS2 – Input

Select in menu “2.9 INPUT → OPERATION MODE“ which function will be executed when applying a signal.

GWS/Tare:                      The limit value set 1 (GWS1) is utilized. In addition, external tare is possible by applying a high level to this input.

GWS 1+2:                      Both limit value sets can be activated (see following chart).

The parameters (Set points) of the limit value sets are set in menu “2.9 INPUT → LIMIT VALUE SETS“.

Logic State	2.9 INPUT → OPERATION MODE →	
	Input TARE/GWS2	GWS/TARE                      GWS 1+2
Low Level	<b>GWS1 used</b> with SP1_1 and SP2_1. No tare	<b>GWS1 used</b> with SP1_1 and SP2_1.
High Level	<b>GWS1 used</b> with SP1_1 and SP2_1. Tare is performed.	<b>GWS2 used</b> with SP1_2 and SP2_2.

BMS plug: Tare/GWS2                      Signal (Pin5)    0V (Pin11 or Pin12)



### 6.3 Digital Outputs – Limit Values (SP1 and SP2)

For each limit value set, 2 switching points (SP1 and SP2), independent from each other, can be configured in value and switching direction. The second limit value set is activated by the control input **Tare/GWS2**. This requires setting **GWS 1+2** in mode "2.9 INPUT → OPERATION MODE"

Limit Value Set	GWS1	GWS2
Set point 1 (SP1)	SP1_1	SP1_2
Set point 2 (SP2)	SP2_1	SP2_2

The closing contact is located at the BMS plug.

SP1: Pin14 and Pin15

SP2: Pin7 and Pin8

Technical details of the closing contacts:

**Dissipation loss max.: 500mW**

Current max.: 400mA

Tension max.: 60V

On state resistance: ~1Ω

### 6.4 Key Assignment in the Menu

- Switch on: Press ENTER
- ▲: Scroll up (keep key pressed → automatic display of the next character etc.)
- ▼: Scroll down (keep key pressed → automatic display of the next character etc.)
- ENTER: Confirm, one step forward in the menu
- ESC: Discard, one step back in the menu
- Switch off: ESC – key  
If the GM 80-TG/-PA is in menu 1 MEASURE, it can be switched off by pressing ESC > 3 sec.

### 6.5 Operation Examples

- With power supply, the GM 80-PA is immediately in the measuring mode of the previously selected parameter set.
- The GM 80-TG is activated by pressing ENTER.
- Check time and date in menu mode SYSTEM and adjust if necessary.
  - Adjust language  
Enter menu mode 2 SYSTEM – 2.1 LANG. When the **ENTER** key is pressed, the GM 80-TG/PA Measuring Amplifier is in the selection mode. With key ▲ or ▼ the language can be selected. With **ENTER**, the selected language will be stored. Now, the menu is displayed in the selected language. With **ESC**, the selected language is discarded.
  - Adjust time  
Enter menu mode 2 SYSTEM – 2.8 TIME. Select TIME. When the **ENTER** key is pressed, the actual adjusted time will be displayed. Press **ENTER** again and the time can be adjusted. Adjust the hours with key ▲ or ▼. Press the **ENTER** key again and the minutes can be adjusted with key ▲ or ▼. Press **ENTER** and time will be stored. By **ESC**, the currently adjusted time will be discarded
- Change to measuring mode  
In menu mode 1 MEASUR, a list of all sensors is called by pressing **ENTER** the list of all sensors is called. With key ▲ or ▼ a sensor parameter set can be selected. By **ENTER** the GM 80-TG/PA Measuring Amplifier is being adjusted to this sensor parameter set. The **ESC** key allows to return to the menu mode 1 MEASUR from any menu mode.
- Change measuring rate from the measuring mode  
The measuring mode can be left by pressing **ESC**. After pressing **ESC** again, the GM 80-TG/PA Measuring Amplifier is in menu mode 1 MEASUR. From there, the menu mode 2 SYSTEM – 2.4 Rate can be called. Select RATE by key ▲ or ▼. By pressing **ENTER** the first adjusted measuring rate is displayed. By key ▲ or ▼ a new measuring rate can be adjusted. By **ENTER** the new measuring rate will be taken over, by **ESC** the new measuring rate will be discarded
- Switch-off the GM 80-TG Measuring Amplifier  
In menu mode 1 MEASUR, the GM 80-TG Measuring Amplifier can be switched-off by pressing **ESC** >3 sec.



- Switch-off the GM 80-PA Measuring Amplifier  
This device can only be switched off by disconnecting the power supply.

## 6.6 Measuring with the GM 80-TG/-PA

Description with an example:

### 6.6.1 Selected Sensor

Force sensor, meas. range:	200kN
Sensitivity.:	2mV/V
Designation e.g.:	PRESS
Parameter set: sensor no.:	3
Option:	100 % control signal

### 6.6.2 Sensor Parameters

After entering the password (9373) in menu mode 2SYSTEM-2.5PASS, the sensor can be applied in the adjustment menu.

Following parameters are available:

Sensor__	Sensor no. 3	Sensor 0 – 9 possible
POINTDIS	200,0	Adjust meas. range and decimal point (max. 9999)
UNIT	_kN	1 – 3-digit unit possible
DESIGN	Press	Up to 8 digit name (or numbers) freely selectable
ADJUST	PAS_wCON	Select "Passive with 100 % control signal". See sensor data sheet.
0% LOAD	Unload sensor	0% sensor value is assigned to display 0.
100% CON	Autom. adjustment	100% sensor value is assigned to display 200,0kN.
SAVE	<b>ENTER</b> or <b>ESC</b>	Confirm or discard

### 6.6.3 Measuring with the GM 80-TG/PA Measuring Amplifier

In order to measure with this sensor, the sensor "Press" is selected in the measuring mode. During the measurement, a minimum and maximum value buffer can be accessed with key ▼. The displayed minimum or maximum value in each case can be deleted by pressing **ENTER**.

If the measured value will be sent to a pc or printer via an interface, the appropriate interface must be selected, the baud rate must be matched to the recipient and in SCI-MODE, the operating mode must be chosen. For example: HAND, a measured value with time is displayed each time you press **ENTER** during the measurement.

For data logging, adjust the operating mode in the logger mode, e.g. choose AUTO and interval time e.g. 10 sec and go to the measuring mode. A measured value with time is now stored every 10 sec. In mode LOGGSEND, these data can then be sent via the interface

**Note:**



During operation with a USB-interface, the baud rate must also be set correctly. It must match the baud rate of the virtual COM port of the receiving PC.



## 6.7 GM 80-TG/-PA Brief Operation Overview

### GM 80 program overview

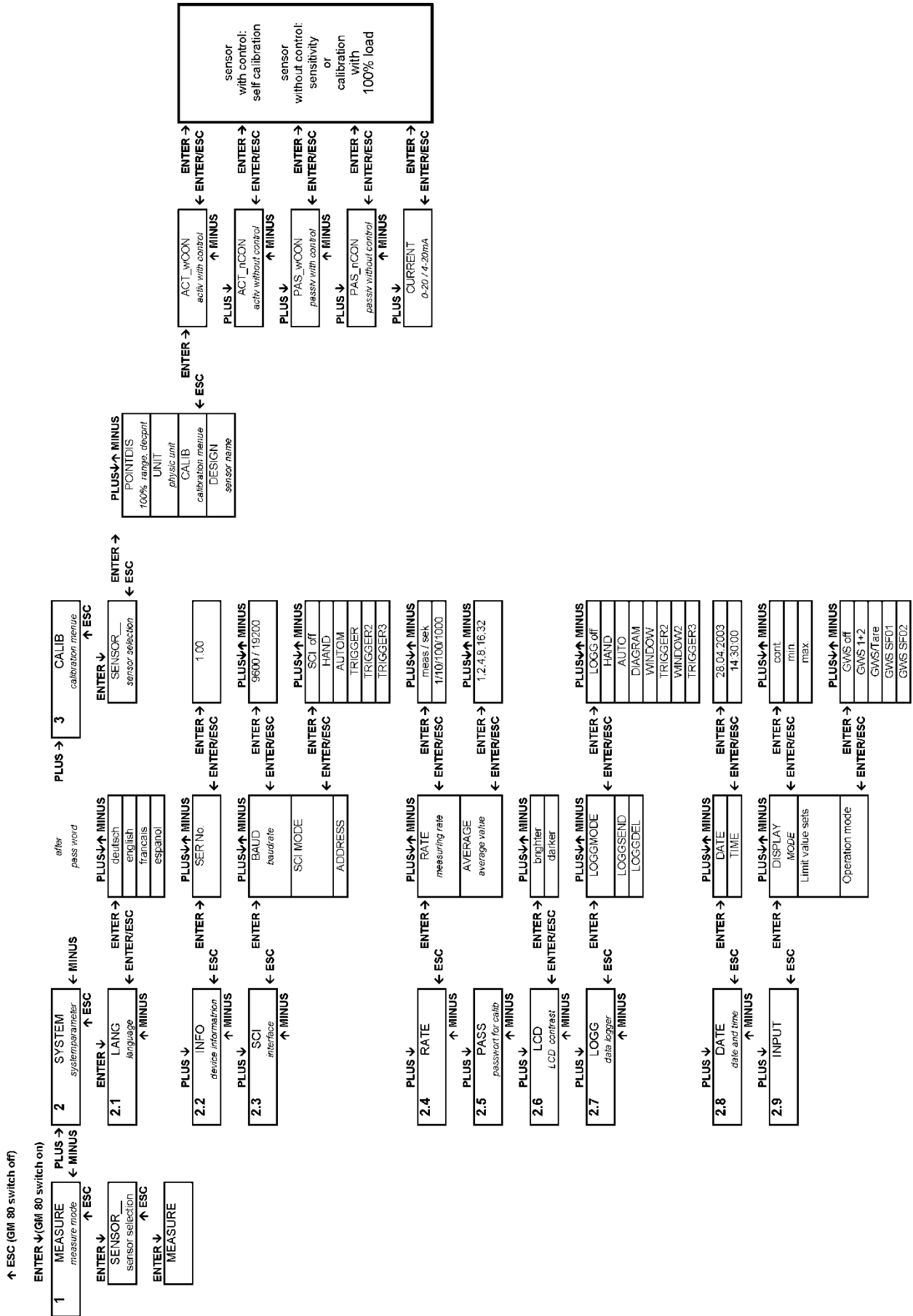



## 6.8 Menu Description

<b>1 MEASURE</b>	<b>Measuring mode</b>
SENSOR__	Sensor selection for measuring mode, Sensor 0 – 9 Selection of the sensor parameter set for the measurement. The sensor parameter set must comply with the connected sensor.
<b>2 SYSTEM</b>	<b>All system parameters are stored in this menu column.</b>
<b>2.1 LANG</b>	<b>Language adjustment</b> The menu language is available in English, German, French and Spanish.
<b>2.2 INFO</b>	<b>Information query was factory-configured and is not modifiable.</b>
SW no.	Firmware version, important for technical questions
<b>2.3 SCI</b>	<b>Interface configuration</b>
BAUD	Baud rate adjustment; it must comply with the receiver (Pc or printer).
SCI MODE	<b>The interface configuration only refers to the measuring mode, not the log mode!</b>
SCI off	Interface switched off
HAND	When pressing <b>ENTER</b> in the measuring mode, a measured value is displayed.
AUTO	Interval time, adjustable from 10ms to 1h (at high measuring rate only possible with the highest baud rate).
TRIGGER	At a trigger pulse, a measured value is issued.
TRIGGER2	At a trigger pulse, a measured value is issued and the MIN-MAX-value is deleted.
TRIGGER3	At the first rising edge, a measured value is logged. The second rising edge is skipped.
ADDRESS	Address selection.
<b>2.4 RATE</b>	<b>Measuring rate<sup>1</sup> and average value</b>
RATE	Measuring rate adjustment, selectable from 1/s to 1000/s. For fast procedures (screw joint, insert press...) always select a fast measuring rate, e.g. 1000/s, for very slow procedures select a small rate, e.g. 1/s.
AVERAGE	Average determination, the numbers indicate the average determination by the amount of measurements. Applicable for e.g. vibrations, control oscillations...
<b>2.5 PASS</b>	<b>Password query</b> Entering password <b>9373</b> allows to change to menu <b>3 ADJUST</b> . Here, the sensor parameters can be changed.
<b>2.6 LCD</b>	<b>LCD-Contrast setting</b> If the LCD becomes unreadable by external influences, e.g. solar radiation, heat or cold, the LCD contrast can be corrected here.
<b>2.7 LOGG</b>	<b>Data logger settings</b>
LOGG MODE	Data logger configuration
LOGG off	Off-switch for logger operation, measuring mode possible, only.
HAND	With each keystroke on <b>ENTER</b> a log value is accepted.
AUTO	Adjustment of the measurement intervals for the automatic measured value storing.
DIAGRAM	With each rising edge of the trigger signal, a log value is accepted.
WINDOW	The window operation is started by a rising trigger edge and can be finished only by a falling edge. During this time, measured values are stored in 1ms raster in the data logger.
TRIGGER2	With each rising edge of the trigger signal, a log value is accepted and the MIN – MAX – value is deleted.
WINDOW2	Same as TRIGGER2
TRIGGER3	At the first rising edge, a measured value is logged. The second rising edge is skipped.
LOGGSEND	Log values are issued through the interface, press <b>ENTER</b> twice.
LOGG DEL	Log values are deleted after a safety query. Before deleting, please assure that the data was received as requested.
<b>2.8 TIME</b>	<b>Date and time setting</b>
DATE	Date
TIME	Time



<b>2.9 INPUT</b>	<b>Operation mode and limit value adjustments</b>
DISPLAY	Setting of the measured value in the measuring mode
cont	Continuous measurement is displayed
min	Minimum measured value is displayed (see ,v' at algebraic sign)
max	Maximum measured value is displayed (see ,v' at algebraic sign)
LIMIT	Limit values are only active if GWS (= limit value set) was selected in the operating mode
SP1_1	Switch point 1 of (GWS1) switch point and switching direction settable
SP2_1	Switch point 1 of (GWS2) switch point and switching direction settable
SP1_2	Switch point 1 of (GWS2) switch point and switching direction settable
SP2_2	Switch point 2 of (GWS2) switch point and switching direction settable
OPER.MODE	Operation mode adjustment
GWS off	All limit values and external tare are switched off
GWS/TARE	GWS 1 and external tare is active
GWS 1+2	GWS 1 and 2 is active, GWS 2 is activated via the control input
GWS SF01	Instantaneous value memory
GWS SF02	Peak value memory
<b>3 CALIB</b>	Menu for calibration and scaling of a sensor (active, passive or current)
	This menu point is active only, if the password has been correctly entered in 2.5PASS. The sensor must be connected to the sensor plug for this procedure.
Sensor_#	Sensor number or name of the sensor to be calibrated
POINTDIS	Measuring range with decimal indication of the sensor, e.g. 100,0; 200,0; 63,00;... Go to menu "POINTDIS", after pressing <b>ENTER</b> the final value of the sensor can be entered, by ▲ or ▼ the digit can be edited, by pressing <b>ENTER</b> the next figure can be edited, if all figures are edited, adjust the decimal point by ▲ or ▼. For the completion of the input press <b>ENTER</b> again, after that, the final value is stored in the GM 80-TG/PA.
UNIT	Input of the physical unit (e.g. kg, Ncm, t, gr, kN, N·m, bar...)
DESIG	Name of the sensor, e.g. sensor 1, 2, 3, DR-2112, silo, tank, mixer, scale1, motor, test1..
CALIB	Sensor type selection (active, passive, 4 – 20mA, with or without control signal)



## 6.9 Calibration/Adjustment Procedure

### **ACT wCON Active sensor with control signal**

With following adjustment possibility:

- After pressing **ENTER**, the automatic adjustment procedure is started. The device first reads in the 0% load value and displays WARM UP. Then the 100% load value is read-in and WARM UP is displayed again. After this procedure, the device displays SAVE? Either confirm this display by pressing **ENTER** to store the adjusted values in the GM 80-TG/PA, or press **ESC** to cancel.

### **ACT\_nCON Active sensor without control signal**

Following selections are available:

- adjust 0% load and 100% load
- adjust 0% load and enter hub [100% load in V – 0% load in V]
- enter 0% load in V and the hub [100% load in V – 0% load in V]

By pressing  $\blacktriangle$  or  $\blacktriangledown$  0% LOAD or the nominal value can be selected.

0%LOAD unload sensor

or NOMVALUE input of the nominal value in V.

By pressing  $\blacktriangle$  or  $\blacktriangledown$  100% LOAD or the nominal value can be selected

100%Load adjustment by 100 % load (apply the nominal load)

or NOMVALUE input of the nominal value in V:

SAVE Query for takeover of the adjusted data.

### **PAS wCON Passive sensor with control signal**

With following adjustment possibility:

- After pressing **ENTER**, the automatic adjustment procedure is started. The device first reads in the 0% load value and displays WARM UP. Then the 100% load value is read-in and WARM UP is displayed again. After this procedure, the device displays SAVE?. Either confirm this display by pressing **ENTER** to store the adjusted values in the GM 80-TG/PA, or press **ESC** to cancel.

### **PAS nCON Passive sensor without control signal**

Following selections are available:

- adjust 0% load and 100% load
- adjust 0% load and enter 100% load in mV/V
- enter 0% load in mV/V and 100% load in mV/V

By pressing  $\blacktriangle$  or  $\blacktriangledown$  0% LOAD or the nominal value can be selected.

0%LOAD unload sensor

or NOMVALUE input of the nominal value in mV/V.

By pressing  $\blacktriangle$  or  $\blacktriangledown$  100% LOAD or the nominal value can be selected

100%Load adjustment by 100 % load (apply the nominal load)

or NOMVALUE input of the nominal value in mV/V

SAVE Query for takeover of the adjusted data.

### **CURRENT Sensor with 4 – 20mA**

Following selections are available:

- adjust 0% load and 100% load
- adjust 0% load and enter 100% load in mA
- enter 0% load in mA and 100% load in mA

By pressing  $\blacktriangle$  or  $\blacktriangledown$  0% LOAD or the nominal value can be selected.

0%LOAD unload sensor

or NOMVALUE input of the nominal value in mA (fixed value 4-20mA).

By pressing  $\blacktriangle$  or  $\blacktriangledown$  100% LOAD or the nominal value can be selected

100%Load adjustment by 100 % load (apply the nominal load)

or NOMVALUE input of the nominal value in mA

SAVE Query for takeover of the adjusted data.



**If no sensor can be selected and/or the sensor does not enter into the measuring mode, the sensor/parameter set was not adjusted correctly. → Re-adjustment**



## 6.10 Edit and Adjust Limit Values

In menu point 2 SYSTEM - 2.9 INPUT - Setpoint the limit value parameters can be adjusted. If menu LIMIT VALUE SETS is selected and confirmed by **ENTER**, the limit values are listed. Switch to the next limit value with **▲**. With **▼** the switching level HI or LO can be selected.

Definition of the switching levels:

- HI... if the measured value exceeds the SP, the output will be switched on.  
if the measured value falls below the point of hysteresis (SP minus approx. 1%), the output will be switched off.
- LO.. if the measured value exceeds the SP, the output will be switched off.  
if the measured value falls below the point of hysteresis (SP minus approx. 1%), the output will be switched on.

The adjusted level is confirmed by pressing ENTER. If ENTER was pressed, the SP can still be edited. The algebraic sign and the digits can be adjusted with **▲** or **▼**. Go to the next digit with ENTER. By confirming with ENTER, the new adjusted SP is taken; with ESC the new adjusted SP is discarded.

## 6.11 Configuration and Adjustment of the Peak Value and the Instantaneous Value Memory

Applied components:

- GM 80-TG/PA
- 1x Sensor
- 2x NI proximity switches (enable and trigger)

General:

GWS SF01 (instantaneous value memory):

With a high impulse on Enable Input the trigger sequence can be set on start position.  
The limit value outputs are set until the next rising edge.

Trigger function: 1.rising edge:

- first everything is set to initial position (switch off GWS)
- then, the limit values are evaluated with the actual measured value

Trigger function: 1.falling edge:

- no action occurs at a falling edge

Trigger function: 2. rising edge:

- no action occurs at a rising edge

Trigger function: 2.falling edge:

- no action occurs at a falling edge

GWS SF02 (peak value memory):

With a high impulse on Enable Input the trigger sequence can be set on start position.  
The limit value outputs are set until the next rising edge.

Trigger function: 1.rising edge:

- first everything is set to initial position (Reset min.- and max.-measured value)

Trigger function: 1.falling edge:

- here, limit value evaluation is carried out via the min.- and max.-measured value

Trigger function: 2.rising edge:

- no action occurs at a rising edge

Trigger function: 2.falling edge:

- no action occurs at a falling edge



**Measuring Arrangement**

All signal inputs and all signal outputs are connected at the BMS-Connector (equipment connector).

The proximity switch is connected to the Enable Pin for the basic position. The second proximity switch is connected to the trigger pin.

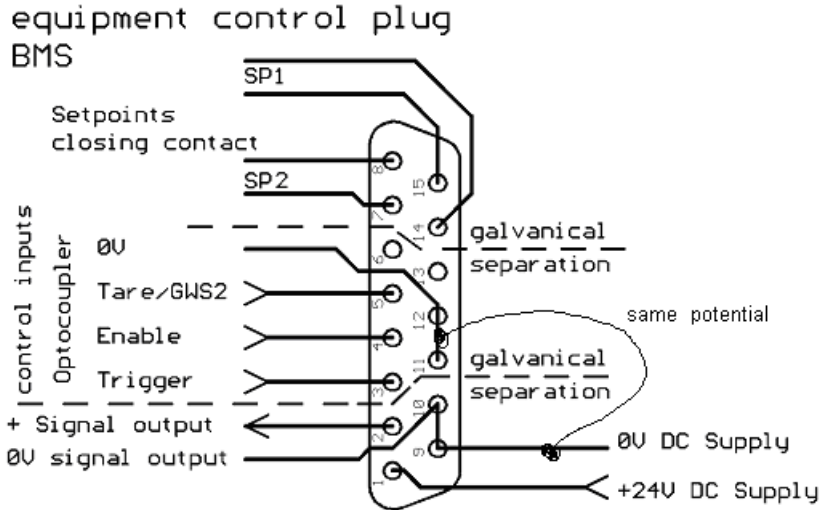

Konfiguration des GM 80-TG/-PA:

The GWS SF01 (instantaneous value memory) or GWS SF02 (peak value memory) function are adjusted in menu 2 SYSTEM → 2.9 INPUT → OPERATION MODE.

The limit values, from which the outputs are switched, are adjustable in menu 2 SYSTEM → 2.9 INPUT → LIMIT VALUE.

The representation type of which measured value is evaluated, is adjusted in menu 2 SYSTEM - 2.9 INPUT - DISPLAY.

Here are following possibilities:

- cont ... the continuous measured value is evaluated
- max ... the MAX measured value is evaluated
- min ... the MIN measured value is evaluated



### Evaluation and Representation

#### Instantaneous Value

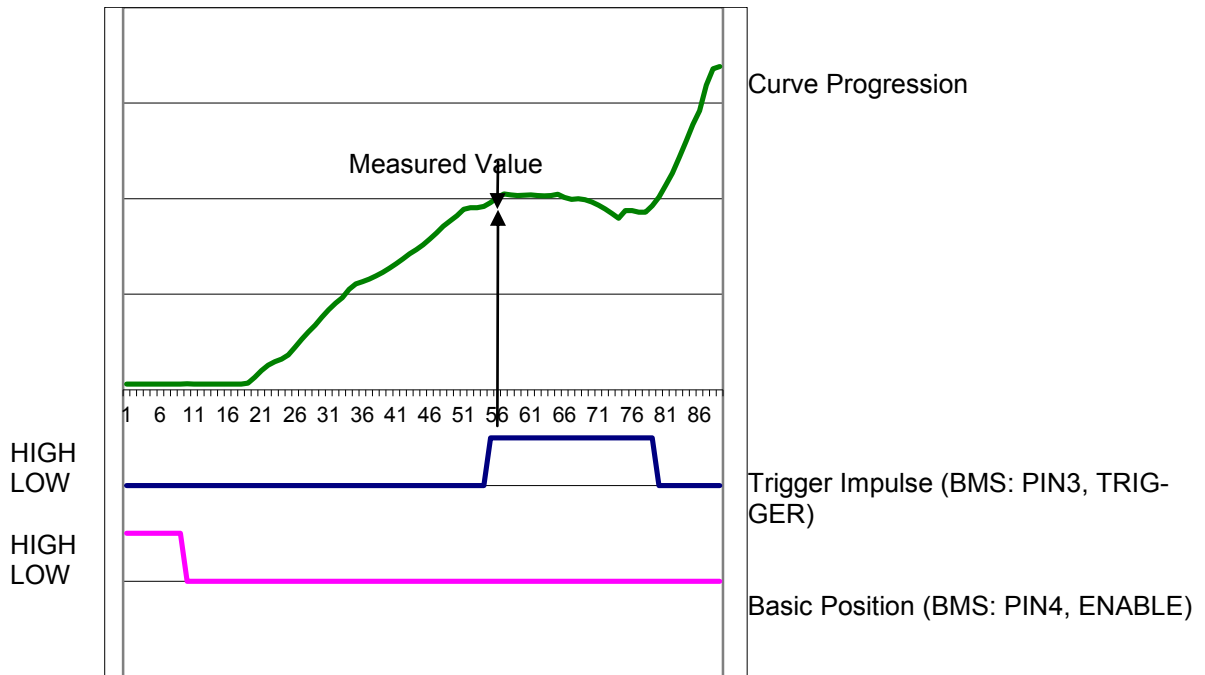

The evaluation and readout occurs when a rising edge is recognized at the trigger pin.

#### Peak Value

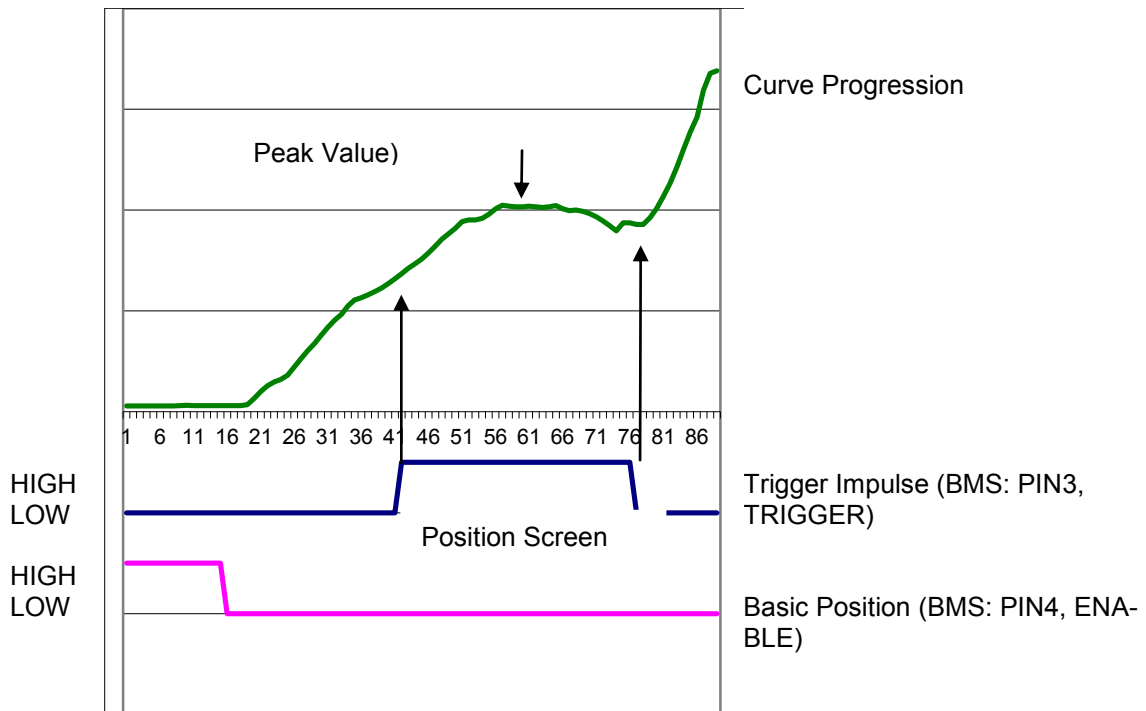

The evaluation occurs, as long as the trigger impulse has a high level. The output occurs after the falling edge.



**Write peak value memory and instantaneous memory from a defined measured value into the data logger:**

General:

The recording starts from a defined measured value. If a rising edge is detected, the measured values are stored inverted. At falling edge, inversion is reset. By the time and duration of the inversion, the trigger time and the duration of the triggering is determined.

If this option is used, following settings must be made beforehand:

Configuration of the GM 80-TG/PA:

- Set "2.7 2.7 LOGG → LOGGING-MODE → WINDOW "
- Set "2.9 INPUT → DISPLAY → CONT"
- "2.9 INPUT → LIMIT VALUES → SP1\_2" here, the threshold level can be adjusted.
- Set "2.9 INPUT → OPERATION MODE → GWS SF01" or „GWS SF02“

### Evaluation and Representation

GWS SF01 is adjusted in the OPERATION MODE. The threshold level when starting the recording is 350. The first trigger pulse was after 235ms, the duration was 220ms. The second trigger pulse was after 615ms; the duration was 250ms. The correct curve progression can be represented by an inversion of the trigger times.



GWS SF02 is adjusted in the OPERATION MODE. The threshold level when starting the recording is 350. The first trigger pulse was after 1290ms, the duration was 585ms. The second trigger pulse was after 2390ms; the duration was 460ms. The correct curve progression can be represented by an inversion of the trigger times. In the peak value memory the peak value is maintained at the falling edge of trigger 1.

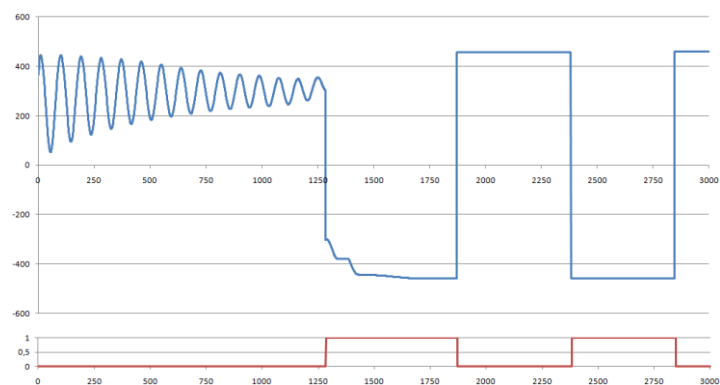



## 6.12 Serial Interface

### 6.12.1 Transfer rate/specification RS232 / V.24

Parity:	none	} 8N1
Number of data bits:	8 (1Byte)	
Stop bit:	1	
Baud rate	settable (2400; 4800; 9600; 19200; 38400; 115200 Baud)	



The baud rate of the GM 80 TG/PA must match with the baud rate of the connected device.

### 6.12.2 Protocol overview

Via the serial interface, the GM 80-TG/PA Measuring Amplifier can issue the measured values individually or automatically. The commands can be send to the GM 80-TG/PA Measuring Amplifier via a terminal program or a PLC. If several devices are connected to the RS-232-BUS, none of these devices shall be operated in the SCI-Mode "AUTO".

Protocol Setup:

0x02    0xXX

STX    Address (see „2.3 SCI → ADDRESS“)

0xXX

Command (see Fehler! Verweisquelle konnte nicht gefunden werden. command overview)

At the device with address 0x00, all parameters (company head, sensor designation ....) are issued when changing into the measuring mode. If these parameters shall not be issued, an address unequal 0x00 must be entered.

#### 6.12.2.1 Command overview

ASCII	HEX	Description	In Measuring Mode	Not in Measuring Mode
k	0x6B	ENTER	✓	✓
l	0x6C	▲	✓	✓
m	0x6D	▼	✓	✓
n	0x6E	ESC	✓	✓
A	0x41	Read-out data logger	✓	✓
C	0x43	Read-out current sensor parameters	✓	✓
D	0x44	Read-out status	✓	✓
E	0x45	Read-out complete status	✓	✓
g	0x67	Change protocol setup	✓	✓
0	0x30	Continuous measured value query (signed integer)	✓	
1	0x31	Query of max. value (signed integer)	✓	
2	0x32	Query of min. value (signed integer)	✓	
3	0x33	Tare of display	✓	
4	0x34	Reset max. value	✓	
5	0x35	Reset min. value	✓	
6	0x36	Actuate 100 % 100 % control signal – for sensors with 100 % control resistance	✓	
7	0x37	Switch-off 100 % 100 % control signal – for sensors with 100 % control resistance	✓	
B	0x42	Delete data logger	✓	
a	0x61	Write time		✓
b	0x62	Read-out time		✓
c	0x63	Write company head		✓
e	0x65	Write all sensor parameters (not supported yet)		✓
f	0x66	Read- all sensor parameters (not supported yet)		✓



In menu 3: ADJUST→UNIT and ADJUST-DESIG, the adjustments cannot be changed by the commands "l" and "m".



**6.12.2.2 Read-out of actual sensor parameters**

Sensor designation	8Byte	ASCII
Final display value	2Byte	packed BCD-number
Unit	3Byte	ASCII
Sensor type and digit	1Byte	0xAB: A ... 0xAB: A ... Sensor type, B ... digit (binary coded)

Sensor type:  
0xXXXX XXXX

```

| | | |
0000 ...active with 100 % control signal adjust 0%Load and 100%Load
0001 ...active without 100 % 100 % control signal adjust 0%Load and 100%Load
0010 ...active without 100 % 100 % control signal adjust 0%Load and 100%Load V
0011 ...active without 100 % 100 % control signal adjust 0%Load V and 100%Load V
0100 ...passive with 100 % 100 % control signal adjust 0%Load and 100%Load
0101 ...passive without 100 % 100 % control signal adjust 0%Load and 100%Load
0110 ...passive without 100 % 100 % control signal adjust 0%Load V and enter
      100%Load in mV/V
0111 . passive without 100 % 100 % control signal enter 0%Load mV/V and enter
      100%Load in mV/V
1000 ... Current          adjust 0%Load and 100%Load
1001 ... Current          adjust 0%Load and enter 100%Load in mA
1010 ... Current          enter 0%Load in mA and enter 100%Load in mA

```

Digit:  
0xXXXX XXXX

```

| | | |
|000 ... 5000
|001 ... 5,000
|010 ... 50,00
|011 ... 500,0
|100 ... 5,000

```

0%Load	2Byte	HEX-value (MSB/LSB)
100% Load	2Byte	HEX-value (MSB/LSB)

**6.12.2.3 Read-out status**

Status	2Byte	General error condition of the GM 80-TG/-PA
--------	-------	---

**6.12.2.4 Read-out complete status**

Status	2Byte	General error condition of the GM 80-TG/-PA
Meas. rate	1Byte	0x01 ... 1000/s 0x02 ... 100/s 0x03 ... 10/s 0x04 ... 1/s
Average value	1Byte	0x01 ... x/1 0x02 ... x/2 0x04 ... x/4 0x08 ... x/8 0x10 ... x/16 0x20 ... x/32
SCI_MODE	1Byte	0x00 ... interface is off mode 0x04 ... hand mode 0x08 ... automatic mode 0x0C ... trigger mode
SCI_MODE_DELAY	1Byte	0x02 ... 10ms 0x03 ... 100ms 0x04 ... 1s 0x05 ... 10s 0x06 ... 1min 0x07 ... 10min 0x08 ... 1h
LOGGMODE	1Byte	0x00 ... logger is off mode 0x04 ... hand mode 0x08 ... automatic mode 0x0C ... DIAGRAM mode 0x10 ... windows mode
LOGGMODE_DELAY	1Byte	0x01 ... 1ms 0x02 ... 10ms 0x03 ... 100ms 0x04 ... 1s 0x05 ... 10s 0x06 ... 1min 0x07 ... 10min 0x08 ... 1h
Language	1Byte	0x00 ... GERMAN 0x02 ... ENGLISH 0x04 ... FRENCH 0x06 ... SPANISH
Protocol status	1Byte	0xXXXX XXXX (binary coded)

```

| | | | | |
| | | | |1 ... do not send final character
| | | | |1 ... send CR/LF
| | | | |1 ... send CR
| | | | |1 ... send LF

```

**6.12.2.5 Write time**

Writing time is the same as the data block for the receipt of time. However, the data block for writing is secured with a check sum and the associated weighted check sum.

**6.12.2.6 Read time**

With following read-out:  
DAY.MONTH.YEAR  
2xSpace



HOURS:MINUTES:SECONDS

**6.12.2.7 Read company head**

By this command, the company head, which is stored in the GM 80-TG/-PA is read-out.

**6.12.2.8 Write company head**

The entry ends either if 256 characters are received or if the character ETX (0x03) Strg-C is contained in the character string.

**6.12.2.9 Write all parameters**

The writing data block of all sensor parameters is identical with the receiving data block for reading all parameters. However, for the writing of the sensor parameters a check sum and the referring weighted checksum is required.

**6.12.2.10 Read all parameters**

The read-out of all parameters from sensor 1 to sensor 10 occurs in following sequence:

Sensor designation

Final displayed value

Unit

Sensor type (adjustment type) / decimal point

Adjustment values 0% Load, 100% Load with 2Bytes each

See command „read current sensor parameters“.

**6.12.2.11 Change protocol setup**

Protocol status	1Byte	0xXXXX XXXX (binary coded)
		1111
		1111 ... do not send final character
		1111 ... send CR/LF
		1111 ... send CR
		1111 ... send LF

**6.12.2.12 Calculation of the Check Sum (CS) and the Weighted Check Sum (gewCS)**

The calculation occurs via all parameter bytes (without the command byte). At the CS all bytes are added (overflows are not considered here). For the calculation of the gewCS, the CS is added to the gewCS. At an overflow, the gewCS is incremented by 1.

**6.12.2.13 Operation via the serial interface**

Formatting of the interface output

Output format in SCI Mode:

HAND:		Algebraic sign, measured value, unit, time and CRLF
AUTO:	10ms	Signed integer and CRLF
	100ms	Signed integer and CRLF
	1s	Algebraic sign, measured value, unit, time and CRLF
	10s	Algebraic sign, measured value, unit, time and CRLF
	1min	Algebraic sign, measured value, unit, time and CRLF
	10min	Algebraic sign, measured value, unit, time and CRLF
	1h	Algebraic sign, measured value, unit, time and CRLF
TRIGGER:		Signed integer and CRLF
TRIGGER2:		Signed integer and CRLF

Output format in LOGG Mode:

HAND:	Algebraic sign, measured value, unit, time and CRLF
AUTO:	Algebraic sign, measured value, unit and CRLF
GRAPH:	Algebraic sign, measured value, unit and CRLF
WINDOW:	Algebraic sign, measured value, unit and CRLF
TRIGGER2:	Algebraic sign, measured value, unit and CRLF

Settings in the SCI-Mode

SCI OFF	In this setting, a transfer of measured values from the GM 80-TG/PA is disabled. However, the GM 80-TG/PA can be addressed with the GM 80 commands.
HAND	In this mode, a measured value is issued via the serial interface when ENTER is pressed at the GM 80-TG/PA.
AUTO	In this mode a measured value is issued via the serial interface in the adjusted delay.
TRIGGER	At a trigger event in this mode, a measured value is issued through the serial interface. The trigger pulses can occur in 10ms raster. The edge of the trigger pulse must be on HIGH for at least 4ms. After that, it must be on LOW for at least 6ms.
TRIGGER2	This mode functions like the trigger mode, but here, the MIN value and the MAX value are reset at a recognized trigger pulse. The display is set back to the display mode which was adjusted in Menu 2.9 INPUT-DISPLAY..



TRIGGER3      At the first rising edge, a measured value is issued; the second rising edge is skipped.

### 6.12.3 Connection to a serial interface

As a single unit, the GM 80-TG/PA can be connected to a PC directly via a serial 1:1 connection cable.

By an internal circuitry, up to 6 devices can be connected parallel to the RS-232 interface. The connection occurs parallel via 1:1 connection (Rx auf Rx, Tx on Tx and GND on GND). The connection to the PC occurs via a zero modem cable. In BUS mode, all GM 80-TG/PA units function as SLAVE, a connected control as MASTER.

### 6.12.4 Operation and function principle of the GM 80-TG/PA

If the GM 80- TG/PA is not in the measuring mode, the data logger can be read by the menu 2.7 LOGG → SENDING or by the command "A" via the interface. Outside of the measuring mode the data logger is deleted by menu 2.7 LOGG → DELETION, only.

If the GM 80 is in the measuring mode, the data logger can be read with the command "A" and deleted with the command "B".

If the measuring mode is being switched on from menu 1MEASURING-sensor selection, the starting time of the measurement, the current sensor designation, the final value of the measuring range, the adjusted measuring rate and the logger mode (e.g.: AUTO 1ms) are stored in the logger.

**NOTE: Here, all previous measured values are deleted!**

When switching on the GM 80-TG/PA, the device immediately switches to the measuring mode. Thus, the previously recorded logger values are deleted. In order to store these logger values, press **ESC** before pressing **ENTER** in menu 1 MEASURING.

Before the data logger-readout via the serial interface, different settings are sent from the GM 80-TG/PA:

- a) Company head
- b) Starting time of the measurement
- c) Sensor designation
- d) Final display value
- e) Adjusted measuring rate
- f) Adjusted logger mode
- g) Thereafter the measured values

In the HANDMODE, the measured values are always logged with the time. The measured value is logged in the AUTOMODE. By the specified starting time, a time can be assigned to each measured value. Since trigger events of less than 1sec can occur in the GRAPHS MODE as well as in the WINDOW MODE, an additional time is not possible at the moment.



## Settings in the LOGG-Mode

LOGG OFF	Here, the data logger is switched off. The log mode is switched to LOGG OFF in the measuring mode as soon as the data logger was fully written.
HAND	In this mode, a measured value is written in the data logger if <b>ENTER</b> was pressed at the GM 80-TG/PA. By an additional time log, the time is assigned to each measured value.
AUTO	In this mode, depending on the adjusted delay, a measured value is written in the logger. By the stored starting time of the measurement, the time can be assigned to each measured value.
GRAPH	At a trigger event in this mode, a measured value is logged. Since the trigger pulses can occur in 10ms raster, an additional time log is not possible. The edge of the trigger pulse must be on HIGH for at least 4ms. After that, it must be on LOW for at least 6ms.
WINDOW	This mode reacts to rising and/or falling edges. At a falling edge, the log of the measured values is started. In the adjusted raster (e.g. 1ms), the measured values are now logged. A falling edge ends the recording.

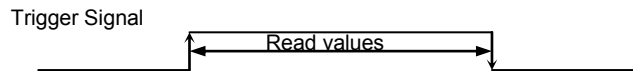

TRIGGER2	See chapter 5.1 for the memory depth of the data logger. This mode functions like the graph mode, but here, the MIN value and the MAX value are reset at a recognized trigger pulse. The display is set back to the display mode which was adjusted in Menu 2.9 INPUT-DISPLAY.
TRIGGER3	At the first rising edge, a measured value is issued; the second rising edge is skipped.



### 6.13 Pin Assignment

connection for sensor plug SUB-D HD fem. 15pol

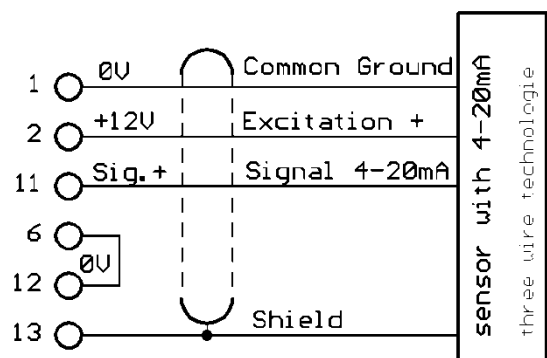
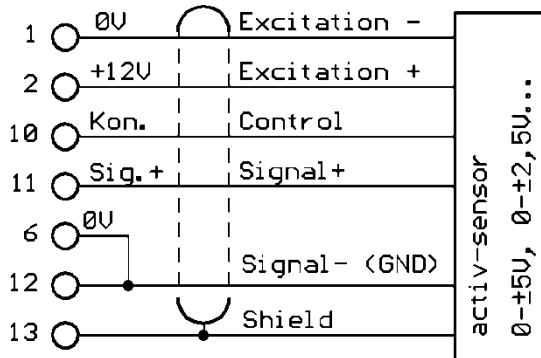
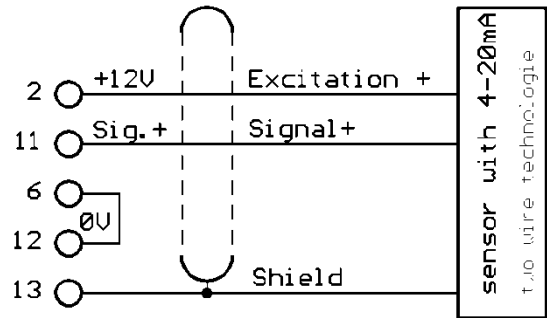
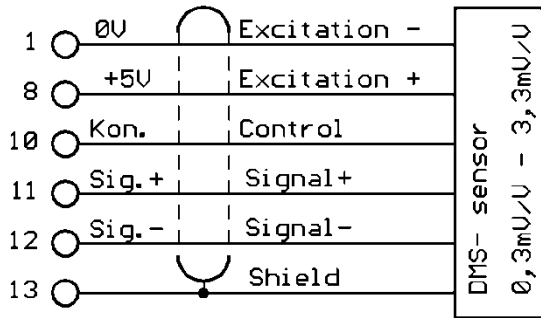

Attention: not connected pins not for use, only reserved for programming in factory!!

only for GM80 TG  
supply connector 2,1mm

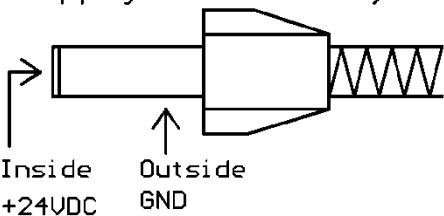

Connector SUB-D male 9 pol.

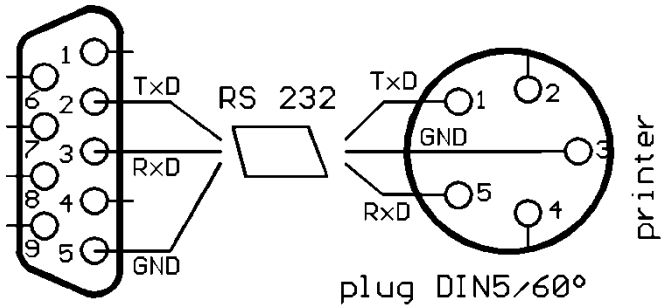

equipment control plug  
BMS

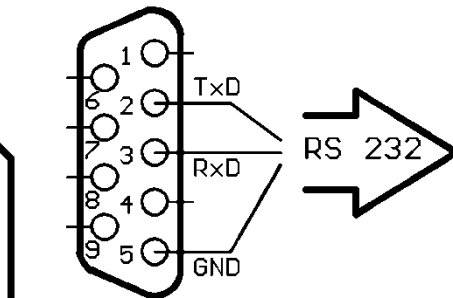
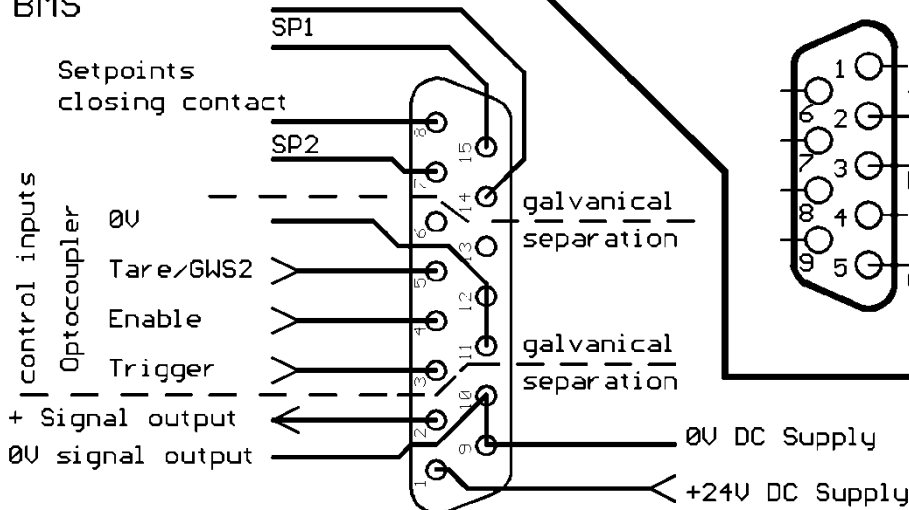



+signal output corresponds to a signal output voltage of  $\sim 2,5V \pm \sim 2,4V$ . The voltage swing ( $\pm \sim 2,4V$ ) and the zero point are depending on the connected sensor. Under load, the voltage swing can be measured with nominal value and at unloaded sensor, the voltage value in the zero point.

### 6.13.1 Connection example digital input (BMS plug)

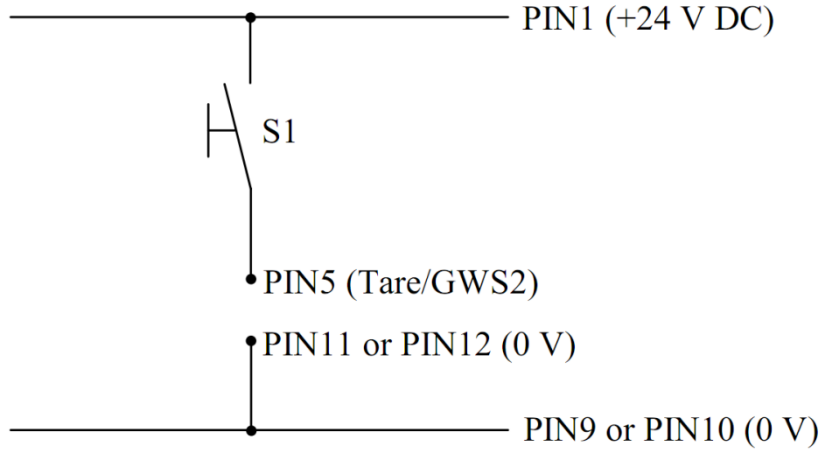

### 6.13.2 Connection example digital input (BMS plug)

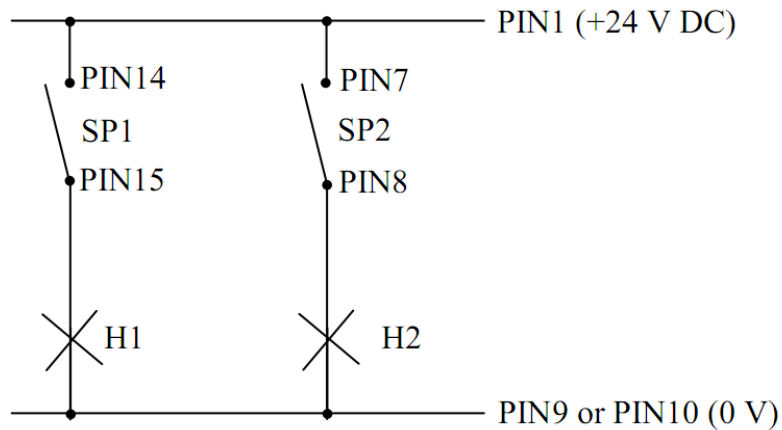



## 7 Product Phases

### 7.1 Transportation

**Note:**



Please pack the equipment suitable for transportation

The equipment may not be able to move back and forth in the package

Please protect the equipment against moisture

### 7.2 Commissioning and Installation

#### Safety measures before the installation:

**Caution:**



The device may not be connected to the power supply system, directly. The supply voltage can be 16...30V.

#### Cable connections:

**Caution:**



Free connections in the 15-pin D connector (programming pins) may never be connected to voltage levels!

### 7.3 Standard Operation

#### EMC:

**Caution:**



The device may not be exposed to higher EMS transients than determined by the standard.

#### Cable:

**Caution:**



Never disconnect the connectors by pulling the cables. Always separate the connector at the plug, directly.

#### Storage

**Note:**



Store the device in dry and dust-free spaces, only.



## 7.4 Maintenance and Cleaning

### Cleaning:

#### Warning:



Please disconnect the device from the power supply before cleaning.

#### Caution:

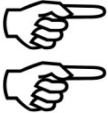

Clean the housing with a soft and slightly moisturized cloth. Never use solvents, as they may damage the front panel labeling and the display panel. While cleaning, ensure that no liquids enter the device or the connections

### Changing the batteries:

#### Caution:



Note the correct polarity of the batteries.

### Preventive maintenance and inspection:

#### Note:



Check the plug connections.

### Repair:

#### Note:



The device does not contain any parts which must or can be serviced by the user. Repairs may be carried out by **Lorenz Messtechnik GmbH**, exclusively. If assuming that safe operation of the device is no longer possible, it must be taken out of service and secured against inadvertent operation, immediately.

This applies in particular, if:

- the device shows visible damage
- the device is no longer functional
- parts of the device are loose
- the connection lines show visible damage

## 7.5 Safe Disposal

### Battery disposal:

End users are required to return used batteries by law (battery ordinance); the disposal with normal waste is prohibited. The used batteries/rechargeable batteries can be returned to our company free of charge, to collecting communities or any place where batteries are sold.

### Equipment disposal:

Please dispose obsolete equipment in accordance with the applicable statutory provisions. By this, you meet the legal obligations and also contribute to the environmental protection!